

Coyote Stainless Steel Side Burner Use & Care Manual

For Liquid Propane and Natural Gas Models

Slide-in Models

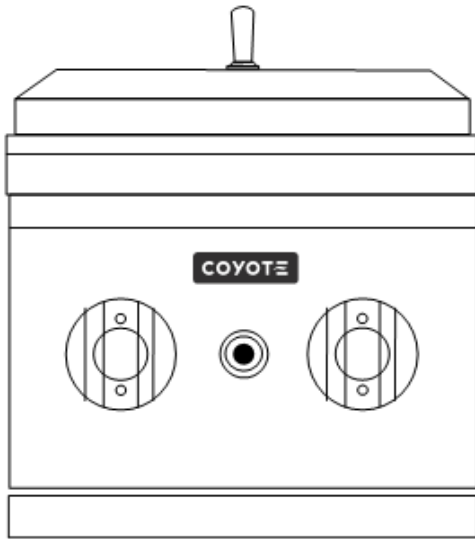

**Coyote S Series – CDSB-LP/CDSB-NG
Dual Slide in Side Burner LP/NG**

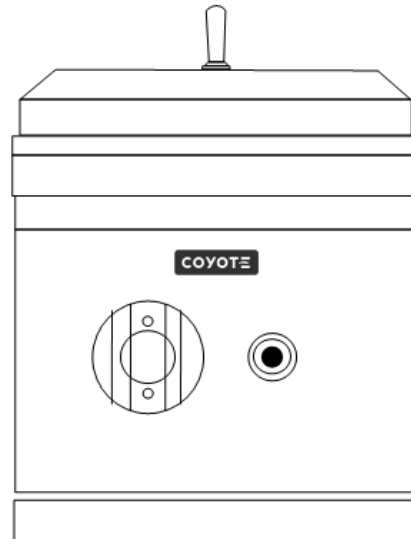

**Coyote C Series – CSSB-LP/CSSB-NG
Single Slide in Side Burner LP/NG**



Conforms to ANSI STD
21.58a-2008
Certificated to CSA STD
1.6a-2008

For Outdoor Use Only

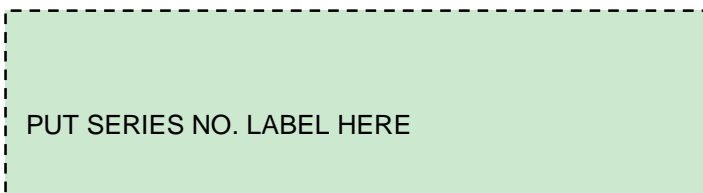

IMPORTANT: Read the lighting instruction on Page 14 before first time use!

To installer or person assembling: Leave this manual with burner for future reference.

To consumer: Keep this manual for future reference.

COYOTE OUTDOOR LIVING, INC.

www.coyoteoutdoor.com

Welcome & Congratulations

Congratulations on your purchase of a new side burner! We are very proud of our products and we are completely committed to providing you with the best service possible. Your satisfaction is our #1 priority.

Please read this manual carefully to understand all the instructions about how to install, operate and maintain for optimum performance and longevity.

We know you'll enjoy your new side burner and thank you for choosing our product. We hope you consider us for future purchases.

Please read and save the instructions

This Manual provides specific operating instructions for your model. Use your side burner only as instructed in this manual. These instructions are not meant to cover every possible condition and situation that may occur. Common sense and caution must be practiced when installing, operating and maintaining any appliance.

Table of Contents

Safety Instructions	2
Side Burner Models	4
Gas Requirement	5
Locating the Side burner	9
Pre Operation Leak Testing	11
Parts List	12
Light the Side burner	14
Operation and Features	16
Care & Maintenance	17
Troubleshooting Your Burner	19
Limited Warranty	21

• WARNING

IF YOU SMELL GAS:

1. Shut off gas to the appliance.
2. Extinguish any open flame.
3. Open Lid.
4. If odor continues, keep away from the appliance and immediately call your gas supplier or your fire department.

Safety Symbols

• WARNING

DANGER indicates an imminently hazardous situation which, if not avoided, will result in death or serious injury.

• WARNING

WARNING:

1. DO NOT store or use gasoline or other flammable liquids or vapors in the vicinity of this or any other appliance.
2. An LP cylinder not connected for use shall not be stored in the vicinity of this or any other appliance.

• CAUTION

CAUTION indicates a potentially hazardous situation which, if not avoided, may result in minor or moderate personal injury, or property damage.

• WARNING

FOR OUTDOOR USE ONLY:

NEVER operate side burner in enclosed areas, as this could lead to gas accumulating from a leak, causing an explosion or a carbon monoxide buildup which could result in injury or death. DO NOT use your side burner in garages, breezeways, sheds or any enclosed area. NOT FOR USE BY CHILDREN. If these instructions are ignored, a hazardous fire or explosion could result in physical injury, death or property damage!

• WARNING

WARNING indicates a potentially hazardous situation which, if not avoided, could result in death or serious injury.

Safety Instructions

WARNING: Improper installation, adjustment, alteration, service or maintenance can cause injury or property damage. Read the installation, operating and maintenance instructions thoroughly before installing or servicing this equipment.

General Safety Instructions

1. For Household Outdoor Use Only – DO NOT use indoors or in any type of enclosed area such as a garage, shed or breezeway. Keep clear of trees and shrubs. The side burners are not intended for installation in or on recreational vehicles, portable trailers, boats or any other moving installation. Not for commercial use.
2. The area surrounding your new side burner should be kept clean and free from flammable liquids and other combustible materials such as mops, rags or brooms, as well as solvents, cleaning fluids, and gasoline.
3. To reduce the risk of serious or fatal injury from breathing toxic fumes and from explosion and fire as a result of leaking gas, use only outdoors in an open area with good ventilation. Do not obstruct the flow of combustion and ventilation air.
4. Never use the side burner in windy conditions. If located in a consistently windy area (oceanfront, mountaintop, etc.) a wind break will be required. Always adhere to the specified clearances listed.
5. Do not leave the side burner unattended while cooking.
6. Do not use natural gas in a unit designed for liquid propane gas or vice versa.
7. Do not use fuel such as charcoal briquettes on the side burner.
8. Keep children and pets away from hot burner. DO NOT allow children to use or play near the side burner.
9. Never attempt to repair or replace any part of the side burner yourself unless specifically recommended in this manual. All other services should be performed by a qualified service technician.
10. Never lean over an open side burner. Do not place clothing or other flammable material on or near the burner. Do not wear loose-fitting clothes or long sleeves while using the side burner as some fabrics can be highly flammable.
11. Have an ABC fire extinguisher accessible. Never attempt to extinguish a grease fire with water or other liquids.
12. Never use aluminum foil on the burner grids, this can alter airflow for proper combustion and also build up heat in the control area causing the knobs and igniter to melt.
13. When using the side burner, do not touch the burner grid or immediate surroundings as these areas become extremely hot and can cause burns.
14. DO NOT allow grease or other hot material dripping from the burner onto valve, hose or regulator, turn off gas supply immediately. After the side burner has cooled, determine the cause and correct it. After cleaning the valve, hose and regulator, perform a leak test before continuing use.
15. Do not heat any unopened glass or metal container of food on the side burner. Pressure may build up and cause the container to burst, possibly resulting in serious personal injury or damage to the side burner.
16. Keep any electrical supply cords away from water or heated surfaces. Electrical cords should be

placed away from walkways to avoid tripping hazard.

17. Keep gas supply lines as short as possible.
18. Never move the side burner when hot.
19. DO NOT use while under the influence of drugs or alcohol.
20. DO NOT store a spare gas cylinder under or near your side burner.
21. Grease is extremely flammable. Let hot grease cool down before attempting to handle or dispose of it.
22. In the event that a burner goes out, turn burner knobs to the full OFF position. Do not attempt to use the side burner until the gas has had time to dissipate.
23. Do not use side burner until leak check has been made.
24. Turn off the cylinder valve when your side burner is not in use.
25. Ensure the control knobs are in "OFF" position when not in use.

CALIFORNIA PROPOSITION 65 - WARNING: The burning of gas cooking fuels generates some byproducts which are on the list of substances which are known by the State of California to cause cancer or reproductive harm. California law requires businesses to warn customers of potential exposure to such substances. To minimize exposure to these substances, always operate this unit according to the Use and Care Manual, ensuring you provide good ventilation when cooking with gas.

Side Burner Models

(Need to describe their main characteristic what a feature that helps to identify or describe recognizably; a distinguishing mark or trait)

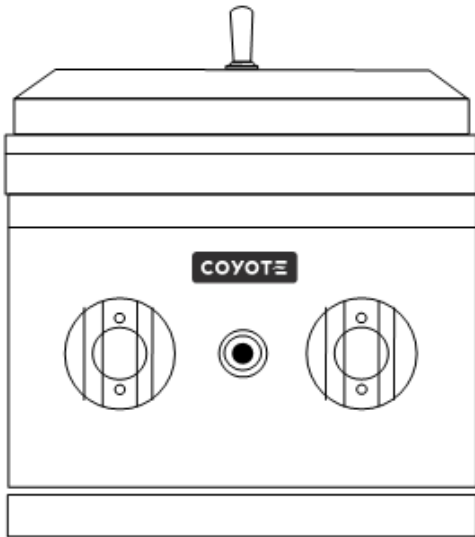

**Coyote S Series – CDSB-LP/CDSB-NG
Dual Slide in Side Burner LP/NG**

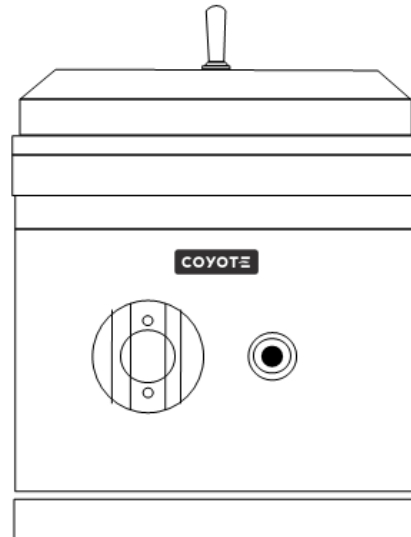

**Coyote C Series – CSSB-LP/CSSB-NG
Single Slide in Side Burner LP/NG**

Model No.	Product Size	BTU	Burner(s)
CDSB / CDSB-NG	13-1/4"(336mm) Width 23"(584mm) Depth 13-1/4"(336mm) Height	30,000	Two brass burners
CSSB / CSSB-NG	11-1/2"(292mm) Width 17"(432mm) Depth 13-1/4"(336mm) Height	15,000	One brass burner

Gas Requirement

NOTE: Always have a qualified service technician perform difficult conversions or modifications.

WARNING: Never attach an unregulated gas line to the appliance. Connection to an unregulated gas line can cause excessive heat or fire.

IMPORTANT: Before connecting side burner to gas source, make sure burner control knobs are in “OFF” position.

Verify the type of gas supply to be used, either natural or LP, and make sure the marking on the appliance rating label agrees with that of the supply.

All pipe sealants must be an approved type and resistant to the actions of LP gas. Never use pipe sealant on flare fittings. The installation of this appliance must conform with local codes or, in the absence of local codes, with either *National Fuel Gas Code, ANSI Z223.1/ NFPA 54, Natural Gas and Propane Installation Code, CSA B149.1, or Propane Storage and Handling Code, B149.2, or the Standard for Recreational Vehicles, ANSI A 119.2/ NFPA 1192M, and CSA Z240 RV Series, Recreational Vehicle Code*, as applicable.

WARNING: Gas valves are preset at the factory to operate on LP or natural gas. If you wish to convert, be sure to contact your dealer FIRST!

LP Gas Hook-up

This propane gas side burner is designed to operate on propane gas ONLY, at a pressure regulated at 11”(279.4mm) water column (W.C.) when equipped with the correct propane orifices on the valves and a propane regulator on the supply line regulated at the residential meter. The LP gas side burner is designed to be used with a standard 20 lbs gas cylinder and must be constructed and marked in accordance with specifications of the US Department of Transportation for propane gas cylinders.

Always keep cylinder securely fastened in an upright position. Never connect an unregulated propane gas cylinder to the side burner.

Do not subject propane cylinders to excessive heat.

CAUTION: Never store a LP gas cylinder inside a building or in the vicinity of any gas-burning appliance.

Cylinder Specifications

- Any L.P. gas supply cylinder used with this appliance must be approximately 12 inches diameter

and 18 inches high. The maximum fuel capacity is 80% and is approximately 20 pounds of propane.

- The L.P. cylinder must have a shut-off valve (see picture) terminating in a Type 1 L.P.
- A Type 1 compatible cylinder with a Type 1 cylinder valve has a back-check valve which does not permit gas flow, until a positive seal has been obtained.
- The cylinder must be arranged for vapor withdrawal. It must also include a collar to protect the cylinder valve. A safety relief device having direct communication with the vapor space of cylinder must be provided. This will expel high pressure gas if the cylinder is overfilled or overheated which could result in fire or explosion.
- All L.P. gas cylinders used with this appliance shall be constructed and marked in accordance with the specifications for L.P. gas cylinders of the U. S. Department of Transportation (DOT) or the *National Standard of Canada, CAN/CSA-B339, Cylinders, Spheres and Tubes for Transportation of Dangerous Goods*; and Commission, as applicable; and shall be provided with a listed overfilling prevention device.
- Read labels on the L.P. Gas Supply Cylinder.
- New cylinders are always shipped empty for safety.
- Allow only qualified L.P. gas dealers to fill or repair your L.P. gas supply cylinder.
- Inform the gas dealer if it is a new or used cylinder to be filled.
- After filling, have the gas dealer check for leaks and to see that the relief valve remains free to function.

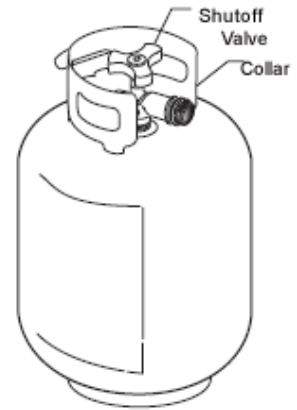

Hose and Regulator

The Type 1 connection system has the following features:

- The system will not allow gas to flow until a positive connection has been made.
NOTE: The cylinder control valve must be turned off before any connection is made or removed.
- The system has a thermal element that will shut off the flow of gas in the event of a fire.
- The system has a flow limiting device which, when activated, will limit the flow of gas to 10 cubic feet per hour.
- **NEVER** use side burner without leak testing this connection.

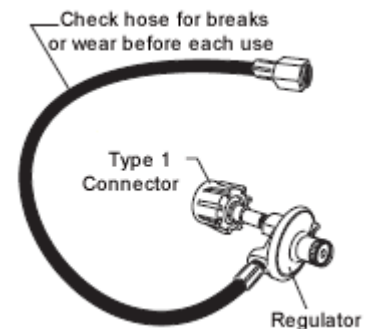

LP(Propane) Gas Supply Connection

1. The tank valve should be in the "OFF" position. If not, turn the knob clockwise until it stops.
2. Make sure all burner valves are in the "OFF" position.
3. Always connect the gas supply regulator as follows:
Insert the regulator inlet into the tank valve and turn the coupling nut clockwise until the coupler tightens up (see picture). Do not over tighten the coupler. Turn the main tank valve on and turn the burner



control valves on the unit to the “HIGH” position for about 20 seconds to allow the air in the system to purge before attempting to light the burners.

WARNING: Always take a leak test before lighting the side burner to prevent a possible fire or explosion. Never store a spare propane cylinder in the vicinity of this side burner, or in the vicinity of any other potential heat source.

LP Gas Supply Cylinder Disconnection

1. Turn the burner valves off.
2. Turn the tank valve off. (Turn clockwise to stop).
3. Detach the regulator assembly from the tank valve by turning the quick coupling nut counterclockwise.

LP Tank Removal, Transport and Storage

- Turn OFF all control knobs and LP tank valve. Turn coupling nut counterclockwise by hand only - do not use tools to disconnect. Lift LP tank wire upward off of LP tank collar, then lift LP tank up and off of support bracket. Install safety cap onto LP tank valve. Always use cap and strap supplied with valve. Failure to use safety cap as directed may result in serious personal injury and/or property damage.
- A disconnected LP tank in storage or being transported must have a **safety cap** installed (as shown). Do not store an LP tank in enclosed spaces such as a carport, garage, porch, covered patio or other building. Never leave a LP tank inside a vehicle which may become overheated by the sun.
- Do not store LP tank in an area where children play.

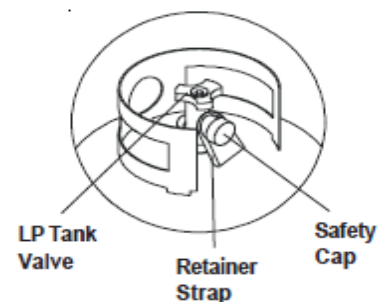

LP Tank Filling

- Use only licensed and experienced dealers.
- LP dealer must purge tank before filling.
- Dealer should NEVER fill LP tank more than 80% of LP tank volume. Volume of propane in tank will vary by temperature.
- A frosty regulator indicates gas overfill. Immediately close LP tank valve and call local LP gas dealer for assistance.
- Do not release liquid propane (LP) gas into the atmosphere. This is a hazardous practice.
- To remove gas from LP tank, contact an LP dealer or call a local fire department for assistance. Check the telephone directory under “Gas companies” for nearest certified LP dealers.

LP Tank Exchange

- Exchange your Type 1 cylinder with OPD safety feature-equipped ONLY.
- Always keep new and exchanged LP tanks in upright position during use, transit or storage. Leak test new and exchanged LP tanks BEFORE connecting to burner.

Natural Gas Hook-up

Always check the rating plate to make sure the gas supply you are hooking up to is the gas type the side burner is manufactured for.

This natural gas burner is designed to operate on natural gas ONLY, at a pressure regulated at 4" (101.6mm) water column (W.C.) when equipped with the correct natural gas orifices on the valves and a natural gas regulator on the supply line regulated at the residential meter.

IMPORTANT: Never connect the burner to an unregulated gas supply.

Natural gas connections must be performed by a licensed contractor or local gas company representative.

Hose and Regulator

IMPORTANT: NEVER use side burner without leak testing this connection.

Natural gas regulator model: GR120N

Gas pressure: 4" (101.6mm)

Quick disconnect model: 1/2QDD-DK

Gas hose connector model: CFN12

Maximum rate working pressure: 1/2 Psig



Natural Gas Supply Connection and Disconnection

1. Make sure all burner valves are in "OFF" position.
2. To connect-push back sleeve of socket, insert Plug release sleeve. Push Plug until sleeve snaps forward locking Plug in Socket. (THIS TURNS GAS AUTOMATICALLY).
3. To disconnect: Push sleeve back and pull out plug. (THIS AUTOMATICALLY SHUTS OFF GAS)
4. Connected hose assembly shall be of adequate length and capacity for intended application. Final assembly must be tested for leaks.

Locating the Side Burner

Check your local building codes for the proper method of installation. In the absence of local codes, this unit should be installed in accordance with the *National Fuel Gas Code No. Z223.1-1998 USA* or *CAN/CGA-B149.1/2 Natural Gas/Propane Code (Canada)* latest edition or the *National Electrical Code ANSI/NFPA No. 70* or the *Canadian Electrical Code CSA C22.1, 1990* or latest version.

- Before installing the side burner in enclosures, copy all product information such as model number, serial number and type of side burner (e.g. natural gas or LP) and store information in a safe place.
- If the side burner is installed by a professional installer or technician, be sure that he shows you where your gas supply shut-off is located. All gas lines must have a shut-off that is readily and easily accessible. If you smell gas, check for gas leaks immediately. Check only with a soap and water solution. Never check for gas leaks with an open flame.

Notice: We strongly recommend professional installation and hookup of the gas side burner. These instructions will provide you with the measurements necessary for you or your builder to construct a masonry structure to house your outdoor gas side burner.

IMPORTANT: Gas fittings, regulator, and installer supplied shut-off valves must be easily accessible.

Location

Locate the side burner only in a well ventilated area. Never locate the side burner in a building, garage, breezeway, shed or other such enclosed areas without an approved ventilation system. During heavy use, the side burner will produce a lot of smoke. Ensure there is adequate area for it to dissipate.

Clearance

- **TO NON-COMBUSTIBLE CONSTRUCTION:** A minimum of 8.5" (217mm) clearance from the back of the side burner is recommended. It is desirable to allow at least 2" (50.8mm) side clearance to non-combustible construction above the cooking surface for counter space. The side burner can be placed directly adjacent to non-combustible construction below the cooking surface. The side burner exhausts combustion products and cooking greases to the back. Never locate the side burner where this exhaust will be difficult to clean.
- **CLEARANCE TO COMBUSTIBLE CONSTRUCTION:** A Minimum of 24" (609.6mm) from the sides and a minimum of 24" (609.6mm) from the back must be maintained from the side burner above and below the cooking surface to adjacent vertical combustible construction.

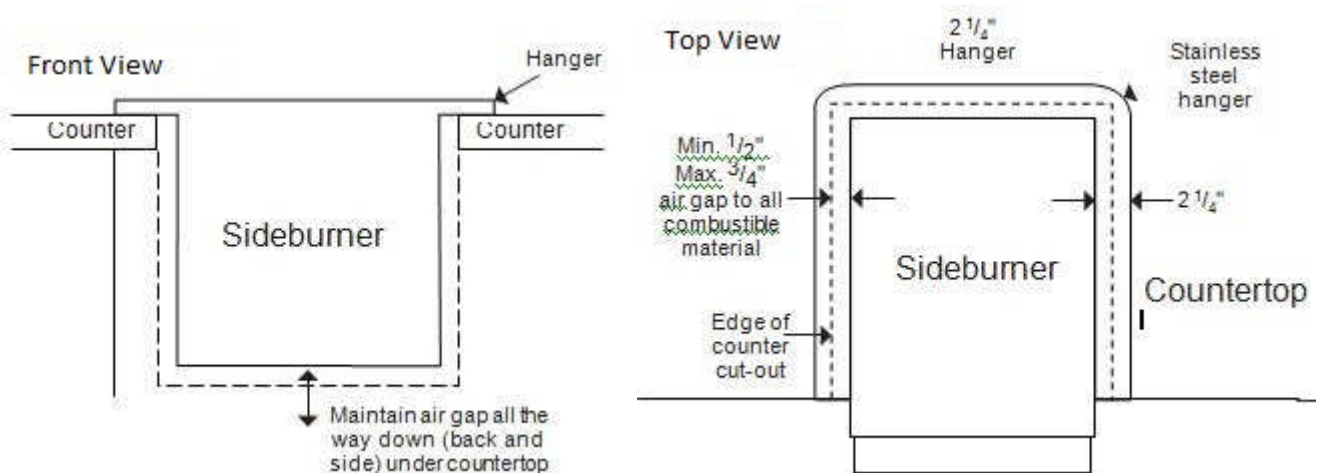

The two top illustrations demonstrate how the slide-in type unit is designed to fit into open- front enclosures, and supported at the Countertop.

Do not install this unit under unprotected flammable surfaces. Do not install or use this appliance inside a building, garage, or any other covered area. It must not be used in or on recreational vehicles or boats.

INSTALLER NOTE: This unit should be installed so that it can be removed at a later date if factory service is required. Any protrusion into the side burner enclosure may prevent the unit from sliding into place.

ENSURING PROPER COMBUSTION AIR AND COOLING AIR FLOW

You must maintain proper airflow for your side burner to perform as it was designed. If airflow is blocked, overheating and poor combustion will result. Make sure not to block the 1" front air inlet along the bottom of the face or more than 75% of the support grid surface with pans or griddles.

For Built-in Installations

A side burner is designed for easy installation into masonry enclosures. For non-combustible applications, the side burner drops into the opening (as shown in cut-out detail - Fig. A) above or below depending on space, and hangs from its counter top trim. A deck is not required to support it from the bottom. It is recommended that the enclosure have ventilation holes to prevent gas build-up in the event of a leak. The deck ledges and counter should be flat and level in reference to the floor.

LP TANK STORAGE AREA MUST BE ISOLATED FROM SIDE BURNER AND VENTED.

Cut out Dimensions figure A

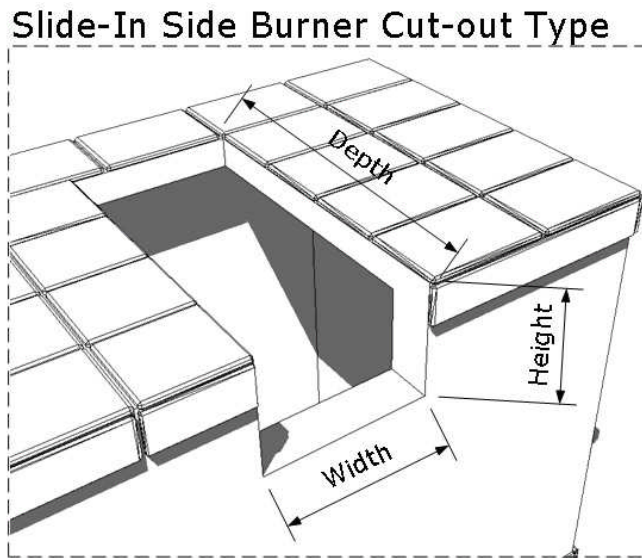

	WIDTH	DEPTH	HEIGHT
Double Burner	12"(305mm)	20-1/2"(521mm)	10-1/2"(267mm)
Single Burner	10-1/2"(267mm)	14"(356mm)	10-1/2"(267mm)

Pre Operation Leak Testing

DANGER

1. Do not insert any tool into the valve outlet or safety relief valve. You may damage the valve and cause a leak. Leaking propane may result in explosion, fire, severe personal injury, or death.
2. If a leak is detected at any time or you cannot stop a gas leak, immediately close pipeline valve and call LP gas supplier or you fire department!
3. Check all gas supply fittings before each use and each time the gas supply cylinder is connected to the regulator. Have a qualified service technician leak test the side burner any time a part of the side burner system is replaced.

WARNING

Never attempt to attach this side burner to the self-contained LP gas system. Do not use side burner until leak testing.

Before Testing

DO NOT smoke while leak testing. Extinguish all open flames. Never leak test with an open flame. Mix a solution of equal parts mild detergent or liquid soap and water.

Leak Testing Valves, Hose and Regulator

1. Turn all side burner control knobs to OFF.
2. Be sure hose is tightly connected to LP tank.
3. Completely open LP tank valve by turning cylinder valve knob counterclockwise (right to left). If you hear a rushing sound, turn gas off immediately. There is a major leak at the connection. Correct before proceeding by calling franchiser for replacement parts.
4. Brush soapy solution onto areas where bubbles are shown in LP tank (see picture).
5. If "growing" bubbles appear, there is a leak. Close LP tank valve immediately and retighten connections.

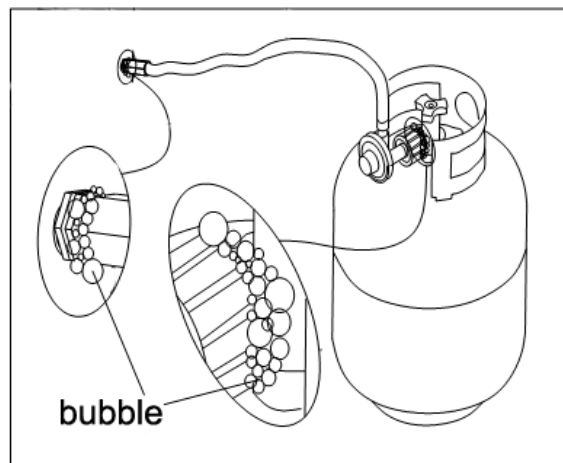

If leaks cannot be stopped do not try to repair. Call franchiser for replacement.

6. Always close LP tank valve after performing leak test by turning cylinder valve knob clockwise.

NOTE: When leak testing this appliance, make sure to test and tighten all loose connections, including the side burner. A slight leak in the system can result in a low flame, or a hazardous condition.

gas tanks now come equipped with a leak detector mechanism internal to the tank; when gas is allowed to escape rapidly, it shuts off the gas supply. A leak may significantly reduce the gas flow making the side burner difficult to light or causing low flames.

Dual Side Burner Parts List

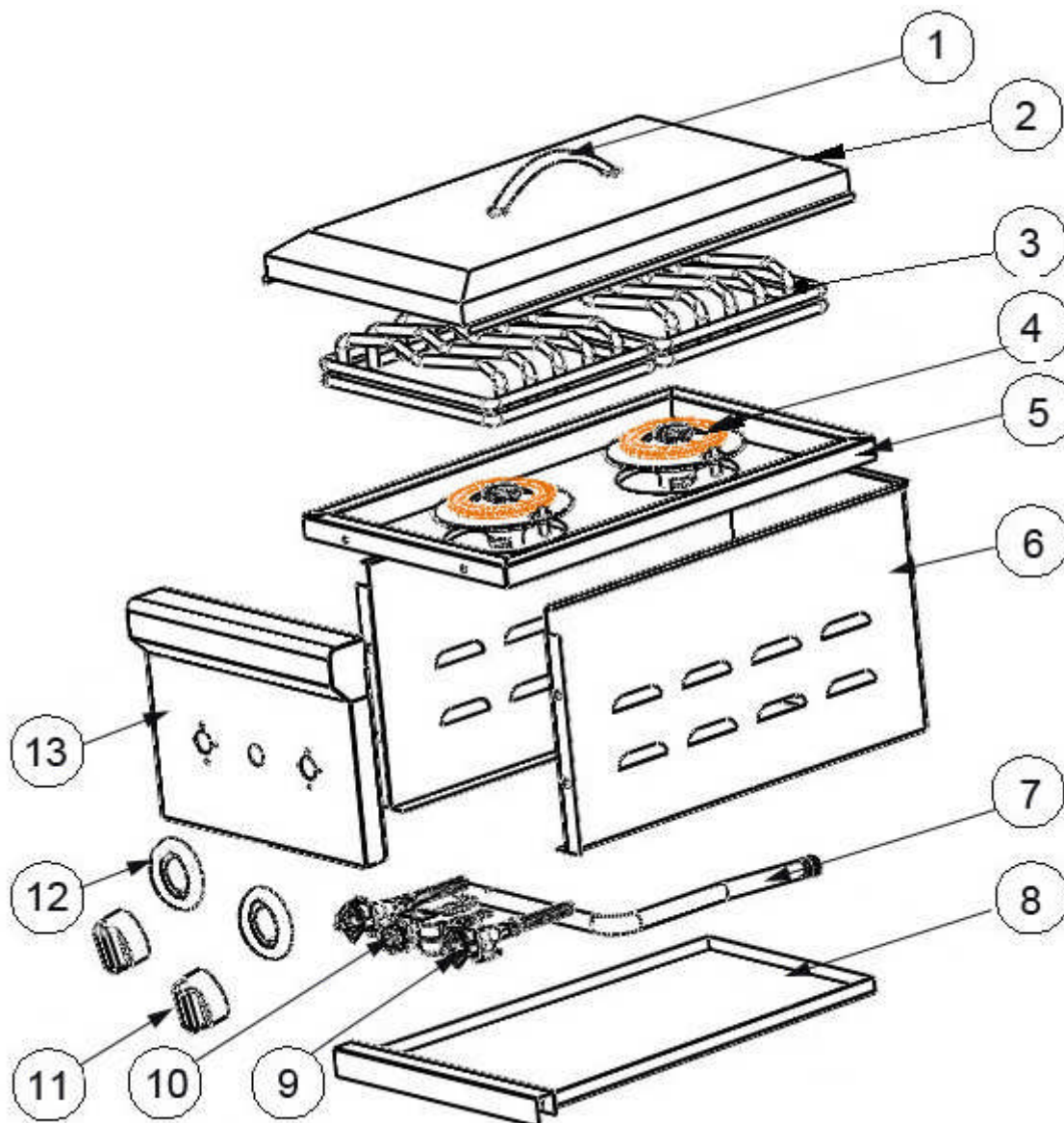

Coyote S Series – CDSB NG/LP PARTS LISTING

No.	Description	Qty	Part No.
1	Lid Handle	1	C0000013
2	Lid-DB	1	CDB00004
3	Grate-SB	2	CSB00004
4	Burner(Side Burner)	2	C0000001
5	Burner Box-DB	1	CDB00001
6	Main Body-DB	1	CDB00005
7	Gas Pipe-DB	1	CDB00008

No.	Name	Qty	Part No.
8	Drip Tray-DB	1	CDB00003
9	Valve - Dual Side Burner-DB	2	CDB00006
10	Igniter	1	C0000008
11	Knob	2	C0000011
12	Knob Base	2	C0000012
13	Control Panel-DB	1	CDB00002

Single Side Burner Parts List

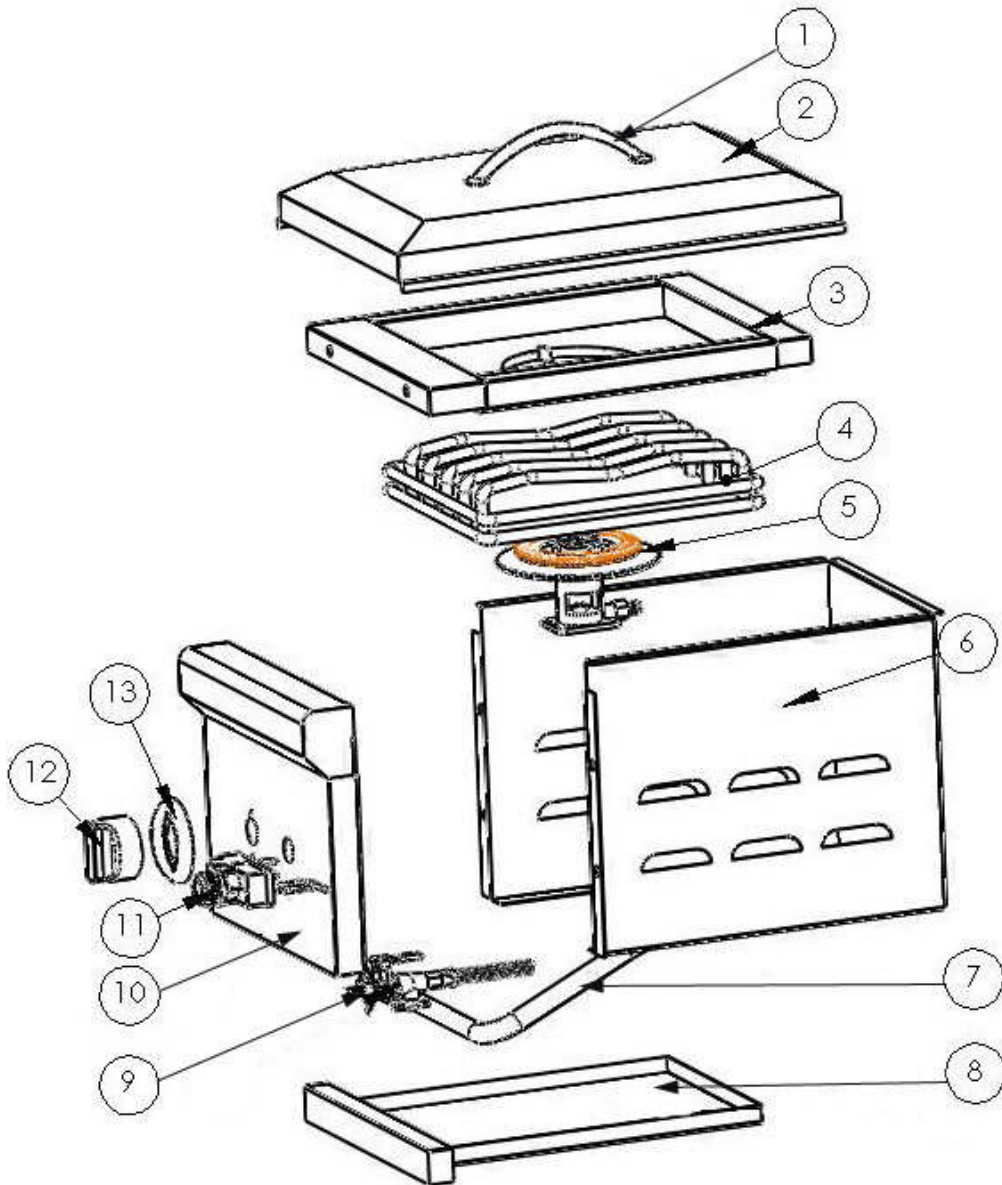

Coyote C Series – CSSB NG/LP PARTS LISTING

No.	Description	Qty	Part No.
1	Lid Handle	1	C000013
2	Lid-SB	1	CSB00006
3	Burner Box-SB	1	CSB00001
4	Grate-SB	1	CSB00004
5	Burner(Side Burner)	1	C000001
6	Main Body-SB	1	CSB00007
7	Gas Pipe-SB	1	CSB00010

No.	Description	Qty	Part No.
8	Drip Tray-SB	1	CSB00003
9	Valve – Single Side Burner-SB	1	CSB00008
10	Control Panel-SB	1	CSB00002
11	Igniter	1	C000008
12	Knob	1	C000011
13	Knob Base	1	C000012

Lighting the Side Burner

DANGER

- Failure to open the lid while igniting the burners, or not waiting 5 minutes to allow the gas to clear if the barbecue does not light, may result in an explosive flame-up which can cause serious bodily injury or death.

WARNING

- DO NOT use the burner if gas odor is present.
- DO NOT stand with head, body, or arms over the burner when lighting.
- Inspect the hose before using the burner. If there is excessive abrasion or wear, or if the hose is cut, it must be replaced prior to the outdoor cooking gas appliance being put into operation. The replacement hose assembly shall be that specified by the manufacturer.
- Ensure the area around the burner is clear of flammable substances such as gasoline, yard debris, wood, etc.
- Ensure there is no blockage of the airflow through the vent space located below the face of the unit.

GENERAL RULES

Do not leave the side burner unattended while cooking!

- Make sure the burner has been leak tested and is properly located.
- Light the burners using the instructions provided in this manual.
- Adjust heat settings to your desired cooking temperature.
- Allow burners to cool down, wipe off any splatters or grease.
- Do not put a cover on the side burner while it is still hot as it could start a fire.

NOTE: If for some reason, igniters fail to light, burners can be lit with a gas lighter.

NOTE: To light gas burner with a gas lighter, make sure the side burner has been leak tested and burners are properly located. Remove the cooking grid from the burner you wish to light. Insert long-necked gas lighter placing near to burner ports. Press in the control knob and rotate left to "HIGH" setting to release gas. Turn on the button on gas lighter, burner should light immediately. Place back the cooking grid and adjust burners to desired cooking temperature.



Keep any electrical supply cords and the fuel supply hose away from any heated surfaces.

Lighting Instructions

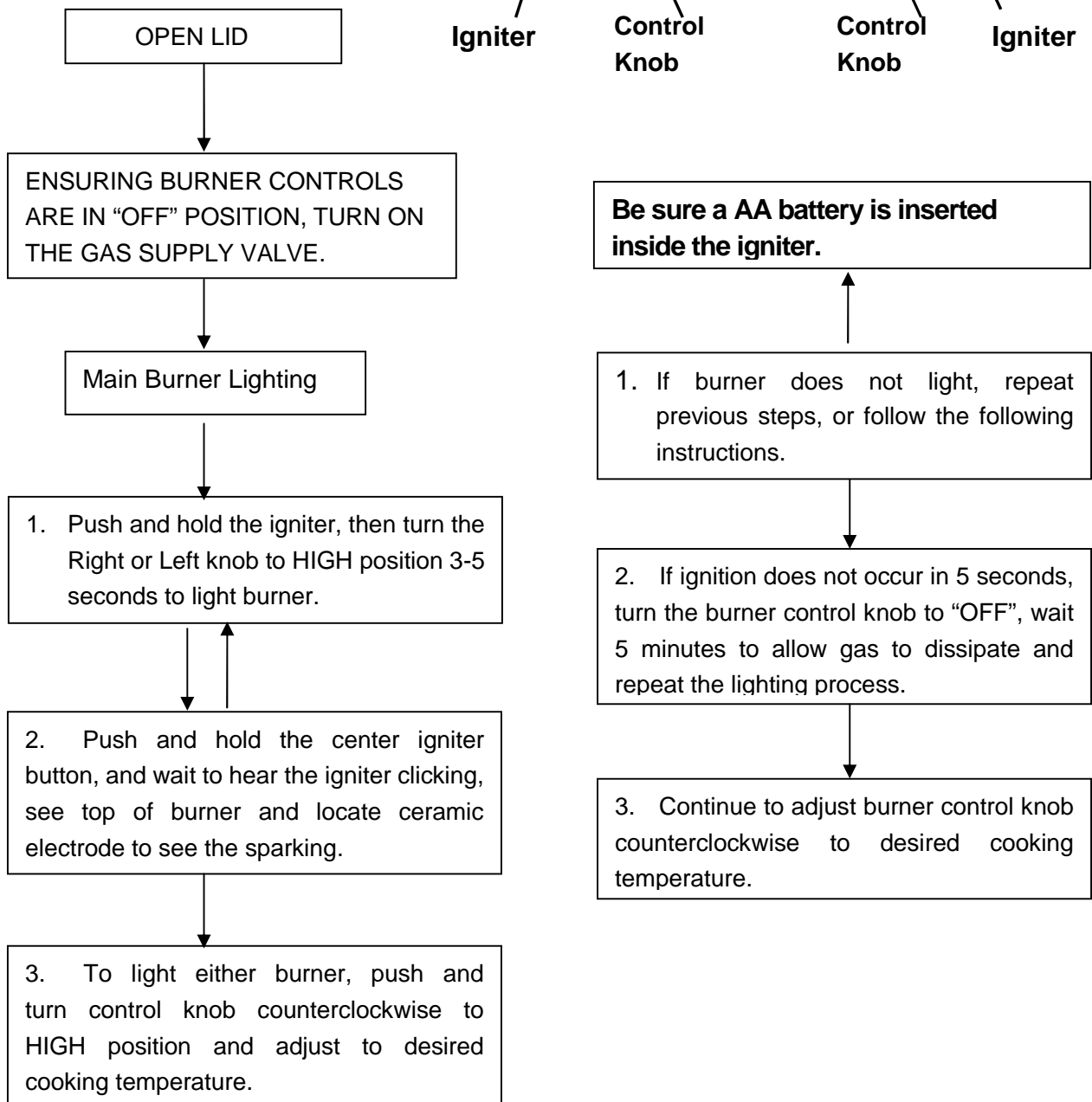
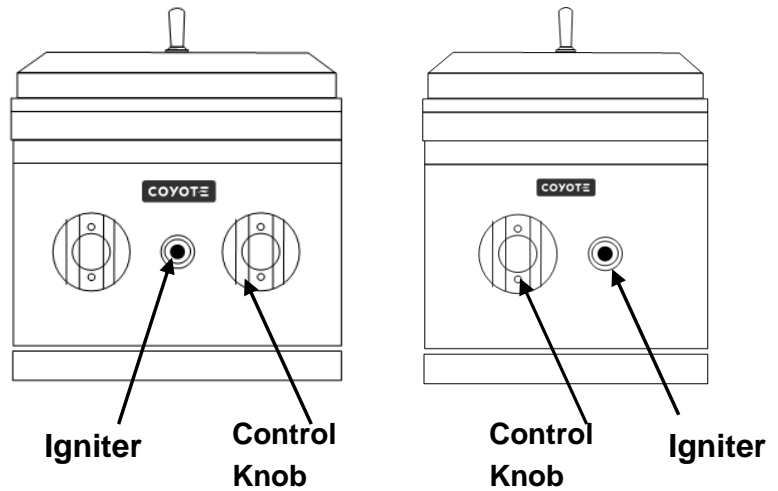

Operations and Features

When initially bringing turning the burners on, burn the burners to get rid of any odors or debris by operating at “HIGH” setting

Preparing Food for the Side Burner

WARNING: Always observe safe food-handling and safe food-preparation practices when using this burner, to prevent food-borne illnesses.

- Always cook foods adequately. Undercooked foods can retain bacteria, especially if thawed or exposed to warm conditions prior to cooking.
- Always use separate plates and utensils for the handling of raw food. Never place raw food and cooked food on the same plate, and never place cooked food on a plate that was used for handling raw food.
- Always carefully wash all plates and utensils used to handle raw food before using them to handle cooked food.
- Always wash all vegetables, seafood and poultry before cooking.
- Always leave uncooked foods in the refrigerator until you are ready to start cooking.
- Always marinate meat in the refrigerator. Dispose of the excess marinade, and never reuse it.

Grilling Tips:

- If you pre-cook meat or poultry, do so immediately before grilling.
- Never defrost meat at room temperature or on a countertop.
- Refrigerate leftovers within 2 hours of taking food off the side burner.
- Never let the tray boil dry. That could be hazardous, as grease from fatty foods that have collected in the tray could ignite and possibly cause bodily injury or property damage.
- Use a meat thermometer to be sure food has reached a safe internal temperature.
- Always trim excess fat from your foods to reduce the occurrence of flare-ups during cooking.
- Apply a light coating of cooking oil to the cooking grids before grilling, to prevent foods from sticking.
- Cook similar portion sizes together, so that they all cook evenly.
- Use tongs to turn foods on the burner.
- Never pierce foods while they are cooking on the burner, as this will dry them out.
- Turn foods infrequently. Some chefs say that a good steak should never be turned more than once.
- Apply sugar-based sauces such as commercial barbecue sauces only during the latter stages of cooking, to prevent charring.

Care & Maintenance

CAUTION: All cleaning and maintenance should be done only when side burner is cool & with the fuel supply turned off at the cylinder. If your side burner is set up for use with Natural Gas, turn off gas supply at the system manual shut off valve.

DRIP PAN

The drip pan located below the burner should be cleaned periodically to prevent heavy buildup of debris.

NOTE: Allow the drip pan to cool before attempting to clean.

IMPORTANT: Do not leave the side burner outside during inclement weather unless it is covered (cover sold separately). If the drip pan is not cleaned after use and the burner is left uncovered, the drip pan will fill with water causing grease and water to spill into the counter. We recommend cleaning drip pan after every use.

COOKING GRATES

The cooking grates can be cleaned immediately after cooking is completed and after turning off the side burner. Wear a barbecue mitt and scrub the cooking grates with a damp cloth. If the burner is allowed to cool down, cleaning the grates will be easier if removed from the burner and cleaned with a mild detergent.

BURNERS

IMPORTANT: Gas control knobs should be in the "OFF" position and fuel line should be disconnected. To reduce the chance of FLASHBACK, the procedure below should be followed at least once a month or when your side burner has not been used for an extended period of time.

1. Remove burners from side burner body by carefully lifting each burner up and away from gas valve orifice. Wire brush entire outer surface of burner to remove food debris and dirt. Clean any clogged ports with a stiff wire such as an open paper clip.
2. Inspect the burner for damage (cracks or holes) and if such damage is found, order and install a new burner.
3. After installation, check to insure that gas valve orifices are correctly placed inside the proper position, also check position of spark electrode.

STAINLESS STEEL

After initial usage, areas of the side burner may discolor from the intense heat given off by the burners. This is normal. Purchase a mild stainless steel cleaner and rub in the direction of the grain of the metal. Specks of grease can gather on the surface of the stainless steel and bake on to the surface and give a worn appearance. For removal, use a non-abrasive oven cleaner in conjunction with a stainless cleaner.

NOTE: Always scrub in the direction of the grain.

ANNUAL CLEANING OF BURNER HOUSING

Burn-off the barbeque after every cookout will keep it ready for instant use, however, once a year you should give the entire side burner a thorough cleaning to keep it in top operating condition.

1. Shut off gas supply at source and disconnects fuel line. Protect fuel line fitting.
2. Remove and clean the cooking grids and burners.
3. Cover the gas valve orifices with a piece of aluminum foil.
4. Brush the inside and bottom of the side burner with a stiff wire brush, and wash down with a mild soap and warm water solution. Wash thoroughly and let dry.
5. Remove aluminum foil from orifices and check orifices for obstruction.
6. Check electrode.
7. Reinstall cooking grids.
8. Reconnect to gas source and observe burner flame for correct operation.

IMPORTANT: You should NOT line the bottom of the burner housing with aluminum foil, sand or any other grease absorbent substance, a grease fire may occur.

MAINTENANCE GUIDELINES

1. Keep outdoor cooking gas appliance area clear and free from combustible materials, gasoline and other flammable vapors and liquids.
2. Do not obstruct the flow of combustion and ventilation air.
3. Keep the ventilation opening(s) of the cylinder enclosure free and clear from debris.
4. Visually check burner flames. Burner flames should be blue and stable with no yellow tips, excessive noise, or lifting. If any of these conditions exist call our customer service line.
5. Clean outdoor cooking gas appliance, including special surfaces, with recommended cleaning agents, if necessary.
6. Check and clean burner for insects and insect nests. A clogged tube can lead to a fire beneath the side burner.

Recommended Cleaners for Specific Situations

JOB	CLEANING AGENTS	COMMENTS
Routine Cleaning	Soap, ammonia, detergent Medallion	Apply with cloth or sponge
Fingerprints & smears	Arcal 20, Lac-O-Nu Ecoshine	Provides barrier film
Stubborn stains & discoloration	Cameo, Talc, Zud First Impression	Rub in direction of polish lines
Grease & Oil	Any good commercial detergent	Apply with sponge or cloth
Restoration/ Passivation	Benefit, Super Sheen	

Troubleshooting Your Side Burner

GENERAL TROUBLE SHOOTING

You should inspect the burners at least once a year or immediately if any of the following conditions occur:

- The smell of gas.
- Flames appearing mostly yellow. (Some yellow at the tips is OK)
- The burners will not get hot enough.
- Burners make a snapping noise.
- The burners heats unevenly.

SPIDER AND INSECT WARNING

INSECT WARNING: Spiders and insects can nest in the burners of this and other burners, which could disrupt gas flow. This dangerous condition could cause a fire behind and beneath the valve panel, damaging the side burner and making it unsafe to operate. We recommend you check the burner and remove any spiders, insects and webs at least once a year to reduce this risk.

WHEN TO LOOK FOR SPIDERS

You should inspect the burners once a year or immediately after any of the following conditions occur:

1. The smell of gas in conjunction with the burner flames appearing yellow.
2. The burner does not reach temperature.
3. The burner heats unevenly.
4. The burners make popping noises.

BEFORE CALLING FOR SERVICE

If the side burner does not function properly, use the chart below before contacting your dealer for service. You may save yourself the cost of a service call. Troubleshooting is for general purposes only. If the problem still exists, contact your dealer or the nearest authorized agency for service.

Problem:	Possible Causes and Solutions:
Burner will not light when the igniter button is pushed.	<ul style="list-style-type: none">• Is your gas supply turned on?• If this is an L.P. side burner, is there gas in your tank? Check your gas level.• Is one of your burners turned on? Allow up to 5 seconds of gas flow to ignite.• Is your igniter working?<ul style="list-style-type: none">- You should hear a snapping sound when you press the igniter.- If you hear a snapping sound, can you see a spark at the electrodes?

	<p>Note: You will need to remove your cooking grates to see the electrodes.</p> <ul style="list-style-type: none"> • Check your igniter battery and replace if needed. • Check for loose wire connections to the igniter or electrodes. • Check to see if debris is blocking the electrodes. • If the igniter is not working, can you light the burner with a lighter?
Flare-ups	<ul style="list-style-type: none"> • Ensure burner is not placed directly in the path of wind. Be sure drip pan is clean (do not use aluminum foil on drip pan.) <p>Note: Some flare-ups may be inevitable if cooking greasy foods.</p>
Yellow Flames	<ul style="list-style-type: none"> • Check the burner inlet for obstructions, particularly at air inlets for each burner. • Side burner should not be in an area that is too windy.
Flame blows out on low setting or has uneven heat distribution.	<ul style="list-style-type: none"> • Check for spider webs or insect nest in venturi and clean venturi. • Cold side burner needs to be preheated for 5 minutes on high setting. • Venturi may be misaligned and needs to be lined up over orifices. • Cold and windy weather will require you to move side burner away from the wind. • Lack of fuel. Check to see cylinder valve is open and cylinder has fuel.
Low heat with the knob on “HIGH”	<ul style="list-style-type: none"> • Check to see if the fuel hose is bent or kinked • Make sure the cooking area is clear of dust • Check your gas supply and gas pressure. • If it is only one burner that appears low, make sure the orifice or burner is clean.
Burner is Too Hot	<ul style="list-style-type: none"> • Excess grease build-up causing grease fires. • Damaged or faulty regulator. Replace with factory authorized parts. • Cook on a lower temperature setting.
Flame behind control panel or control knob area.	<p>IMMEDIATELY shut off cylinder valve and allow side burner to cool.</p> <ul style="list-style-type: none"> • Check for spider webs or insect nest in venturi and clean venturi. • Gas is leaking from a faulty connection. Tighten connections with an adjustable wrench and replace damaged parts. Perform a leak test on all connections before cooking on side burner again. • Venturi may be misaligned and needs to be lined up over orifice.
Fire at any connection.	<p>IMMEDIATELY shut off cylinder valve and allow side burner to cool.</p> <ul style="list-style-type: none"> • Gas is leaking from a faulty connection. Tighten connections with an adjustable wrench and replace damaged parts. • Perform a leak test on all connections before cooking on the side burner again.

Limited Warranty

Coyote Outdoor warrants to the original purchaser at the original site of delivery with proof of purchase of each Outdoor Gas grill/Side burner that when subject to normal residential use, it is free from defects in workmanship and materials for the periods specified below. This warranty excludes grills used in rental and commercial applications. It **does NOT** apply to rust, corrosion, oxidation, or discoloration, which may occur due to moisture or overheating. It **does NOT** cover labor or labor related charges. There will be shipping and handling charge for the delivery of the warranty part(s).

COMPONENT	WARRANTY PERIOD
Burners & Cooking Grids (no rust or burn through)	5 years (limited)
Flavorizer Bars (no rust or burn through).....	2 years (limited)
Electric/Plastic Components	2 years (limited)
Ignition systems/Valves	1 year (limited)
Stainless steel frame/housing	Limited Lifetime

Our obligation under this warranty is limited to repair or replacement, at our option, of the product during the warranty period. The extent of any liability of Coyote under this warranty is limited to repair or replacement. This warranty does not cover normal wear of parts, damage resulting from any of the following: negligent use or misuse of the product, use on improper fuel/gas supply, use contrary to operating instructions, or alteration by any person other than a factory service center. The warranty period is not extended by such repair or replacement.

WARRANTY CLAIM PROCEDURE: If you require service or parts for your Coyote Grill, please contact our Warranty Service Center for factory direct assistance. Our hours of operation are 8 am to 4 pm CST. The phone number is 855.520.1559 and the Fax number is 214.520.1450. You may also fill out warranty claims online at www.coyoteoutdoor.com. **Please have your model number, serial number and proof of purchase available for any warranty claim.**

Coyote Outdoor may require the return of defective parts for examination before issuing replacement parts. If you are required to return defective parts, shipping charges must be prepaid by the customer. Upon examination and to Coyote Outdoor's determination, if the original part is proven defective, Coyote Outdoor, may approve your claim and elect to replace such parts without charge. In any instance, customer is responsible for shipping and handling of the replacement parts. Product repair as provided under this warranty is your exclusive remedy. Coyote Outdoor shall not be liable for any incidental or consequential damages for breach of any express or implied warranty on its products.

This warranty does not cover any failures of operating difficulties or operating difficulties due to accidents, abuse, misuse, alteration, misapplication, vandalism, improper installation, maintenance or service, damages caused by flashback fire or grease fires, as set out in the Owner's Manual. This warranty does not cover scratches, dents, corrosion or discoloration caused by weather, heat, abrasive and chemical cleaners, pool or spa chemicals, and/or any tools used in the assembly or installation of this unit. This warranty does not cover paint loss, surface rust, corrosion or stainless steel discoloration which is considered normal wear and tear. This warranty does not cover the cost of any inconvenience, personal injury, or property damage due to improper use or product failure. Deterioration or damage due to severe weather conditions such as hail, hurricanes, earthquakes, tsunamis, tornadoes, terrorism, discoloration due to exposure to chemicals either directly or in the atmosphere, Acts of God/forces of Nature are not covered by this limited warranty.